

## Gene Localization for an Autosomal Dominant Familial Periodic Fever to 12p13

John Mulley,<sup>1,2</sup> Kathrin Saar,<sup>3</sup> Gerry Hewitt,<sup>5</sup> Franz Rüschen-dorf,<sup>3</sup> Hilary Phillips,<sup>1</sup> Alison Colley,<sup>6</sup> David Sillence,<sup>7</sup> André Reis<sup>3,4</sup> and Meredith Wilson<sup>7</sup>

<sup>1</sup>Department of Cytogenetics and Molecular Genetics, Center for Medical Genetics, Women's and Children's Hospital, North Adelaide; <sup>2</sup>Department of Genetics, University of Adelaide, Adelaide; <sup>3</sup>Mikrosatellitenzentrum, Max-Delbrück Centrum, and <sup>4</sup>Institute of Human Genetics, Humboldt University, Berlin; <sup>5</sup>Wairau Hospital, Blenheim, New Zealand; and <sup>6</sup>Department of Clinical Genetics, Liverpool Health Service, and <sup>7</sup>Department of Clinical Genetics, The New Children's Hospital, Westmead, Sydney

### Summary

We report gene localization in a family with a benign autosomal dominant familial periodic fever (FPF) syndrome characterized by recurrent fever associated with abdominal pain. The clinical features are similar to the disorder previously described as familial Hibernian fever, and they differ from familial Mediterranean fever (FMF) in that FPF episodes usually do not respond to colchicine and FPF is not associated with amyloidosis. Frequent recombination with the marker *D16S2622*, <1 Mb from *FMF*, at 16p13.3, excluded allelism between these clinically similar conditions. Subsequently, a semi-automated genome search detected linkage of *FMF* to a cluster of markers at 12p13, with a multipoint LOD score of 6.14 at *D12S356*. If penetrance of 90% is assumed, the *FPF* gene maps to a 19-cM interval between *D12S314* and *D12S364*; however, if complete penetrance is assumed, then *FPF* maps to a 9-cM region between *D12S314* and *D12S1695*. This interval includes the dentatorubropallidoluysian atrophy locus, which, with *FPF*, gave a maximum two-point LOD score of 3.7 at a recombination fraction of 0. This is the first of the periodic-fever genes, other than *FMF*, to be mapped. Positional candidate genes may now be selected for mutation analysis to determine the molecular basis for FPF. Together with the recent identification of the defective gene in FMF, identification of a gene for FPF might provide new insights into the regulation of inflammatory responses.

Received November 4, 1997; accepted for publication January 27, 1998; electronically published March 27, 1998.

Address for correspondence and reprints: Dr. John Mulley, Department of Cytogenetics and Molecular Genetics, Women's and Children's Hospital, 72 King William Road, North Adelaide, SA 5006, Australia. E-mail: mulleyj@mail.wch.sa.gov.au

© 1998 by The American Society of Human Genetics. All rights reserved. 0002-9297/98/6204-0021\$02.00

### Introduction

The heritable periodic-fever syndromes are a heterogeneous group of rare disorders in which recurrent fever, abdominal pain, and polyserositis are the primary features. Two autosomal recessive (AR) disorders, familial Mediterranean fever (FMF; MIM 249100) and hyperimmunoglobulinemia D and periodic fever (hyper-IgD syndrome, or periodic fever Dutch type; MIM 260920) have been well characterized clinically. A number of families with autosomal dominant (AD) clinical variants have also been described; these variants include Hibernian fever (MIM 142680; Williamson et al. 1982; McDermott et al. 1997), FMF-like syndrome with amyloidosis (MIM 134610; Gertz et al. 1987), periodic fever (MIM 170300; Bouroncle and Doan 1957), and others (Bergman and Warmenius 1968; Reich and Franklin 1970; Hawle et al. 1989; Karenko et al. 1992; Yuval et al. 1995; Mache et al. 1996). The molecular basis has been determined only for FMF (French FMF Consortium 1997; International FMF Consortium 1997). Allelism between FMF and periodic fever Dutch type has been excluded by recombination (Drenth et al. 1994; Livneh et al. 1997).

We report gene localization in an Australian family, of Scottish descent, that segregates an AD familial periodic fever (FPF) resembling Hibernian fever (Williamson et al. 1982; McDermott et al. 1997). The locations for *FPF* (12p13) and *FMF* (16p13.3) will enable investigation of allelism with the remaining AD and AR clinical variants of periodic fever. The positional candidate approach can potentially lead to identification of the gene responsible for FPF in this family.

### Patients, Material, and Methods

#### Clinical Features

The portion of the pedigree relevant to the linkage study is shown in figure 1. Affected family members

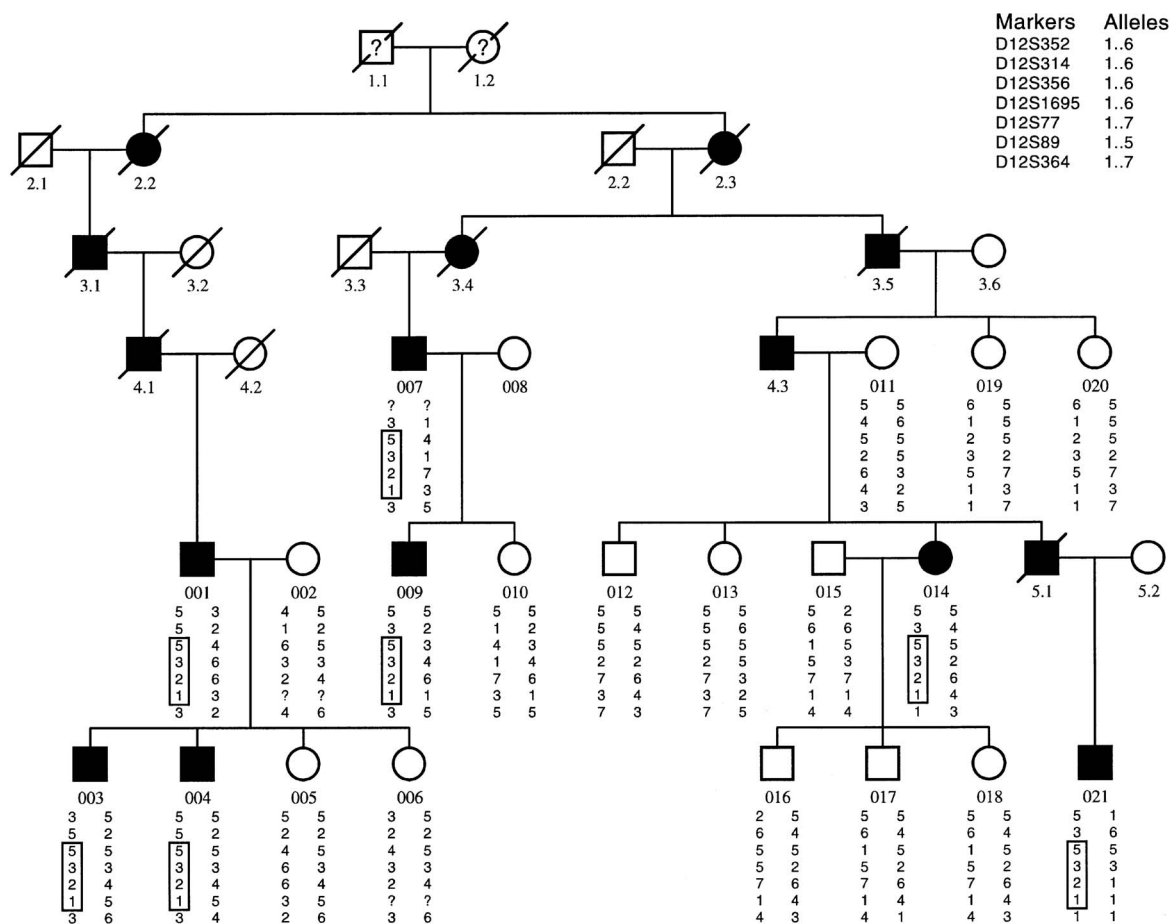

**Figure 1** Pedigree of the family with AD FPF and marker haplotypes from the linked region of chromosome 12. Affected family members share the same marker alleles for *D12S356*, *D12S1695*, *D12S77*, and *D12S89*. The unaffected family member, 006, in the lowest generation, suggests a smaller gene localization, between *D12S314* and *D12S1695*, if 100% penetrance is assumed.

typically manifest symptoms by age 15 years—most by age 10 years. The youngest family member (006) is currently asymptomatic at age 9 years. Fevers are high (40°C) in most affected family members.

The disorder in this family is characterized by episodic attacks of fever and abdominal pain with onset during early childhood or adolescence. The episodes vary in frequency, generally occurring 3–6 mo apart, but may occur as often as every few weeks or as far apart as 10 years. Episodes generally decrease in frequency, with age. The duration of symptoms ranges from days to weeks but, with treatment, can be shortened to 2–3 d. Abdominal symptoms include anorexia, constipation, and colicky abdominal pain, but vomiting is unusual; clinical examination reveals mild abdominal distension and peritonism. Other common symptoms include myalgia, arthralgia, and pleuritic pain. Occasional symptoms include testicular pain and urticarial skin lesions. No patients have mucosal abnormalities or lymphadenopathy.

The fever is unresponsive to paracetamol or aspirin. In most family members, there has been no response to colchicine, but moderate doses of oral steroids have led to resolution of symptoms within 24–72 h. One patient reports rapid improvement with indomethacin.

The family, scattered through various country towns in Australia, has not had consistent medical investigation or treatment. At least three individuals have undergone laparotomy, with or without appendectomy, during acute attacks. Several patients have had markedly elevated erythrocyte sedimentation rates, moderate leukocytosis, and moderate thrombocytosis recorded during episodes. One child had had a single elevated IgD level (between attacks, when asymptomatic), which was normal on repeat testing. This child and three other affected family members had similar mild elevations of IgM, and one had a normal IgD level; no others have yet been tested.

No family member is known to have developed amy-

Table 1

## Pairwise LOD Scores between FPF and Markers on Chromosomes 16 and 12

CHROMOSOME AND MARKER	LOD SCORE AT RECOMBINATION FRACTION OF							$Z_{\max}$	$\theta_{\max}$
	.0	.01	.05	.1	.2	.3	.4		
Chromosome 16:									
<i>D16S523</i>	-9.67	-3.59	-2.07	-1.42	-.80	-.44	-.17		
<i>D16S2622</i>	-10.93	-3.54	-1.96	-1.23	-.55	-.21	-.15		
Chromosome 12:									
<i>D12S352</i>	-5.12	-1.31	-.61	-.35	-.16	-.08	-.02		
<i>D12S314</i>	.24	2.48	2.82	2.67	2.01	1.22	.49	2.82	.05
<i>D12S356</i>	2.40	2.34	2.09	1.78	1.18	.64	.23	2.40	.00
<i>D12S1695</i>	3.14	3.10	2.90	2.62	1.97	1.29	.61	3.14	.00
<i>D12S77</i>	3.98	3.92	3.65	3.27	2.39	1.44	.55	3.98	.00
<i>D12S89</i>	3.58	3.50	3.19	2.79	2.00	1.21	.49	3.58	.00
<i>D12S364</i>	-2.83	-.38	-1.00	1.12	.95	.60	.25	1.12	.01
<i>DRPLA</i>	3.70	3.62	3.31	2.90	2.09	1.28	.53	3.70	.00

NOTE.—Relative position of *DRPLA* is not known.

loidosis. Individual 3.4 died of renal failure at age 70 years, her son (007) had “Bright’s disease” at age 15 years and required dialysis for renal failure during middle age, and his son (009) had an episode of hematuria, diagnosed as nephritis, at age 2 years. He had a rectal biopsy at age 20 years, which showed no amyloid. Individual 5.1 died from colonic cancer. Although amyloidosis was not detected, it is possible that FPF and FMF-like syndrome with amyloidosis are the same disorder. We plan to prepare a separate, detailed clinical report after further investigation of available family members.

#### Genotyping

Venous blood was obtained after informed consent, and DNA was isolated by standard phenol/chloroform extraction. Manual genotyping of the microsatellite markers *D16S523* and *DRPLA* was carried out as described elsewhere (Phillips et al. 1995). Semiautomated genotyping was carried out as described elsewhere (Saar et al. 1997), by use of an ABI 377 sequencer and GENESCAN 2.0 and GENOTYPER V1.1 software. Genotypes were checked for Mendelian segregation, by use of LINKRUN (T. F. Wienker, personal communication).

#### Linkage Analysis

Penetrance was conservatively set at 90%. The feasibility of the linkage study was explored by use of SLINK (Weeks et al. 1990). Two-point LOD scores were computed by the LINKAGE package (Lathrop and Lalouel 1984), and the exclusion map was displayed, for each chromosome, by use of LODVIEW EXCEL V5.0 (Hildebrandt et al. 1993). Multipoint analysis (four-point disease locus and three marker loci) was carried out by use of VITESSE (O’Connell and Weeks 1995). Two-point and multipoint analyses assumed equal marker-

allele frequencies. Haplotyping was carried out by CRIMAP V2.41, with the option CHROMPIC (Green et al. 1990). The pedigree, with haplotypes, was drawn by CYRILLIC.

#### Results

The *FPF* gene, segregating in the pedigree shown in figure 1, was first excluded from the *FMF* region at 16p13.3 (table 1). The marker *D16S523* is <3 cM from *FMF*, and the marker *D16S2622* is <1 Mb from *FMF*. Although both markers are centromeric to *FMF*, *FPF* is excluded from the 5 cM on either side of both markers and is clearly not allelic with *FMF*.

SLINK simulation confirmed that detection of linkage by genome search was achievable for this family; however, because of the absence of key family members, an informative marker might need to be close to the *FPF* gene to detect linkage. A semiautomated genomewide search for linkage was initiated, at 330-marker density. When 236 markers had been genotyped, no evidence could be found for linkage to chromosomes 1–11, 13, or 15–22. However, two-point LOD scores from the subterminal region of the p arm of chromosome 12 (table 1) showed linkage, with a maximum LOD score ( $Z_{\max}$ ) of 3.98 at a maximum recombination fraction ( $\theta$ ) of 0 for *D12S77*. The closest recombinants involving affected family members were at *D12S314* distally and at *D12S364* proximally, which limits the *FPF* gene localization to an interval of 19 cM.

Multipoint analysis (fig. 2) gave a multipoint LOD score of 6.14 at *D12S356* (four-point analysis with *FPF*, *D12S356*, *D12S1695*, and *D12S77*). This confirmed the likely location of *FPF* to the 19-cM interval between *D12S314* and *D12S364*. From the marker haplotype segregating with *FPF* (fig. 1), it can be seen that the

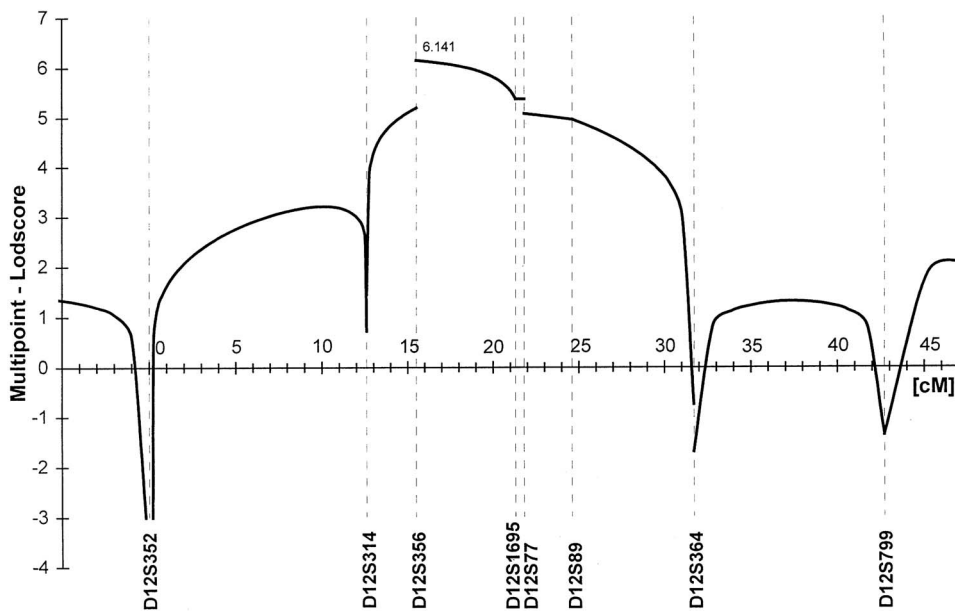

**Figure 2** Multipoint LOD scores, computed by VITESSE, giving a peak LOD score of 6.14 at *D12S356*. (The discrepancies in the heights of LOD scores arise from different informativeness of each set of three markers—the maximum practical number of markers for analysis of this pedigree—with large numbers of family members who have not been genotyped).

unaffected individual (006) sharing part of the affected haplotype has the potential to reduce the localization to a 9-cM interval between *D12S314* and *D12S1695*, when this individual reaches the age at which penetrance of 100% can be assumed. At present, she is almost 9 years old; if she carries the *FPF* gene, she would be expected to show symptoms by age 15 years.

The 12p13.31 region is known to contain the gene for dentatorubropallidolusian atrophy (*DRPLA*). The *FPF* family was genotyped for the polymorphic CAG-trinucleotide repeat, which, when unstable, causes *DRPLA*. Two-point analysis gave a  $Z_{max}$  of 3.70 at  $\theta_{max} = 0$ , which indicates that *DRPLA* and *FPF* are likely to map to the same 19-cM interval between *D12S314* and *D12S364*. Whether *DRPLA* and *FPF* map within the same 9-cM interval between *D12S314* and *D12S1695* will depend on whether individual 006 develops symptoms of *FPF*. If she remains asymptomatic, both *DRPLA* and *FPF* are likely to map within the same 9-cM interval between *D12S314* and *D12S1695*. Conversely, if she becomes symptomatic, the location of *FPF* (but not *DRPLA*) will move to the adjacent segment, between *D12S1695* and *D12S364*.

**Discussion**

The features of various *FPF* disorders are summarized in table 2; however, for more-detailed comparisons, see the work of Livneh et al. (1997) and McDermott et al.

(1997). Although the familial disorder described in the present study resembles Hibernian fever (Williamson et al. 1982; McDermott et al. 1997), allelism to the periodic-fever syndromes other than FMF has not been excluded. Haplotype analysis of a distant lineage related to this family could lead to significant reduction of the regional localization of the *FPF* gene. Such an analysis for AR FMF (Levy et al. 1996; French FMF Consortium 1996) led to diagnosis, based on linkage disequilibrium (Dupont et al. 1997), and to ultimate identification of the defective gene (French FMF Consortium 1997; International FMF Consortium 1997). Alternatively, now that a gene localization has been established, localization may be narrowed by analysis of additional families with this AD condition.

Antonarakis (1994) suggested increasing the efficiency of genome searches by concentrating first on gene-rich regions of the genome. Inglehearn (1997) subsequently presented two sets of markers for selective screening of regions rich in expressed sequence tags. Whereas set B (25 markers) contained none from chromosome 12, set A (40 markers) included *D12S361*, *D12S90*, and *D12S84*. Of these markers, the closest to the *FPF* regional localization is *D12S361*, which is ~30 cM proximal to the *FPF* region (Dib et al. 1996). In this instance, directed genome screening, as suggested by Antonarakis (1994) and Inglehearn (1997), would not have led to more-rapid chromosomal assignment. This result does indicate, however, that the *FPF* gene does not reside in

**Table 2****Comparison between Clinical Forms of FPF**

	Present Family	Hibernian Fever	FMF-like Syndrome with Amyloidosis	FMF	Hyper-IgD
Inheritance	AD	AD	AD	AR	AR
Feature:					
Age at onset (years)	2-15	5-20	<10	<20	<1 (70%)
Abdominal pain	+	+	+	+	+
Myalgia	+	+	?	+	+
Arthralgia	+	+	+	+	+
Skin lesions	± Urticaria, chest	+ Painful erythema arms, trunk, legs	+ Erythema around joints	+ Erysipelas-like lesions below knees	+ Erysipelas-like lesions below knees
Lymphadenopathy	-	-	-	-	+
Amyloid	-	Reported in one patient	+	+	-
Elevated serum IgD	-	-	?	-	+
Elevated acute-phase reactants	+	+	+	+	+
Response to:					
Colchicine	-	-	-	+	-
Steroid	+	+	-	-	-
NSAI	±	±	?	?	-

NOTE.—NSAI = Nonsteroidal anti-inflammatory agents; a plus sign (+) indicates presence; a minus sign (-) indicates absence; a question mark indicates unknown; and a plus-or-minus sign (±) indicates occasional reports.

a gene-rich region, which may be advantageous for gene identification (Inglehearn 1997).

The localization of an AD FPF syndrome to 12p13.3 provides the basis for testing unmapped periodic-fever syndromes, for allelism to the disorder described and mapped in the present study. Allelism between periodic fever Dutch type and FMF was excluded in this way (Drenth et al. 1994), as was allelism between FMF and the disorder described in the present study (table 1), by use of the marker *D16S523*, <3 cM from *FMF* (French FMF Consortium 1996), and the marker *D16S2622*, <1 Mb from *FMF* (Sood et al. 1997). The pattern of inheritance of the family in this study is AD, and the pattern of inheritance in FMF is AR. Defects within the same gene are only rarely known to cause either AR or AD inheritance of the same disorder (Christiano et al. 1996).

Linkage data from a disorder as rare as the one described here are unable to provide a gene localization with the precision necessary to allow initiation of positional cloning. The positional candidate approach may be useful in this circumstance, especially when the *FPF* gene maps to a relatively gene-poor region. The significance of gene identification for FMF (French FMF Consortium 1997; International FMF Consortium 1997) is that any gene product related to pyrin, coded by a gene mapping to 12p13, represents a strong candidate for FPF. Similarly, members of this gene family represent strong candidate loci for other unmapped periodic-fever syndromes.

## Acknowledgments

We thank Bernadette Taylor, for contacting family members and for collecting blood samples; Jill Healy, for SLINK analysis; Jean Spence, for DNA extraction; and the family, for their participation in this study. This study was supported by the National Health and Medical Research Council of Australia and by a grant in aid from the German Ministry of Research (Bundesministerium für Bildung, Wissenschaft, Forschung und Technologie).

## References

- Antonarakis SE (1994) Genome linkage scanning: systematic or intelligent? *Nat Genet* 8:211-212
- Bergman F, Warmenius S (1968) Familial perireticular amyloidosis in a Swedish family. *Am J Med* 4:601-606
- Bouroncle BA, Doan CA (1957) Periodic fever. *Am J Med* 23: 502-506
- Christiano AM, McGrath JA, Tan KC, Uitto J (1996) Glycine substitutions in the triple-helical region of type VII collagen result in a spectrum of dystrophic epidermolysis bullosa phenotypes and patterns of inheritance. *Am J Hum Genet* 58: 671-681
- Dib C, Fauré S, Fizames C, Samson D, Drouot N, Vignal A, Millasseau P, et al (1996) A comprehensive genetic map of the human genome based on 5,264 microsatellites. *Nature* 380:152-154
- Drenth JPH, Mariman ECM, Van der Velde-Visser SD, Ropers H-H, Van der Meer JWM, International Hyper-IgD Study Group (1994) Location of the gene causing hyperimmunoglobulinemia D and periodic fever syndrome differs from

- that for familial Mediterranean fever. *Hum Genet* 94: 616–620
- Dupont M, Dross C, Smaoui N, Nedelec B, Grateau G, Clépet C, Gourdier I, et al (1997) Genotypic diagnosis of familial Mediterranean fever (FMF) using new microsatellite markers: example of two extensive non-Ashkenazi Jewish pedigrees. *J Med Genet* 34:375–381
- French FMF Consortium (1996) Localization of the familial Mediterranean fever gene (FMF) to a 250-kb interval in non-Ashkenazi Jewish founder haplotypes. *Am J Hum Genet* 59: 603–612
- (1997) A candidate gene for familial Mediterranean fever. *Nat Genet* 17:25–31
- Gertz MA, Petitt RM, Perrault J, Kyle RA (1987) Autosomal dominant familial Mediterranean fever-like syndrome with amyloidosis. *Mayo Clin Proc* 62:1095–1100
- Green P, Falls K, Crooks S (1990) Documentation for CRI-MAP, version 2.4
- Hawle H, Winckelmann G, Kortsik CST (1989) Familiäres Mittelmeer-fieber in einer deutschen Familie. *Dtsch Med Wochenschr* 114:665–668
- Hildebrandt F, Pohlmann A, Omran H (1993) LODVIEW: a computer program for the graphical evaluation of LOD score results in exclusion mapping of human disease genes. *Comput Biomed Res* 26:592–595
- Inglehearn CF (1997) Intelligent linkage analysis using gene density estimates. *Nat Genet* 16:15
- International FMF Consortium, The (1997) Ancient missense mutations in a new member of the RoRet gene family are likely to cause familial Mediterranean fever. *Cell* 90: 797–807
- Karenko L, Pettersson T, Roberts P (1992) Autosomal dominant familial Mediterranean fever in a Finnish family. *J Intern Med* 232:365–369
- Lathrop GM, Lalouel JM (1984) Easy calculations of LOD scores and genetic risks on small computers. *Am J Hum Genet* 36:460–465
- Levy EN, Shen Y, Kupelian A, Kruglyak L, Aksentijevich I, Pras E, Balow JE Jr, et al (1996) Linkage disequilibrium mapping places the gene causing familial Mediterranean fever close to *D16S246*. *Am J Hum Genet* 58:523–534
- Livneh A, Drenth JPH, Klasen IS, Langevitz P, George J, Shelton DA, Gumucio DL, et al (1997) Familial Mediterranean fever and hyperimmuno-globulinemia D syndrome: two diseases with distinct clinical, serologic, and genetic features. *J Rheumatol* 24:1558–1563
- Mache CJ, Goriup U, Fischel-Ghodsian N, Chen K, Shwingshandl U (1996) Autosomal dominant familial Mediterranean fever-like syndrome. *Eur J Pediatr* 155:787–790
- McDermott EM, Smillie DM, Powell RJ (1997) Clinical spectrum of familial Hibernian fever: a 14-year follow-up study of the index case and extended family. *Mayo Clin Proc* 72: 806–817
- O'Connell JR, Weeks DE (1995) The VITESSE algorithm for rapid exact multilocus linkage analysis via genotype set-recoding and fuzzy inheritance. *Nat Genet* 11:402–408
- Phillips HA, Scheffer IE, Berkovic SF, Hollway GE, Sutherland GR, Mulley JC (1995) Localization of a gene for autosomal dominant nocturnal frontal lobe epilepsy to chromosome 20q13.2. *Nat Genet* 10:117–118
- Reich CB, Franklin EC (1970) Familial Mediterranean fever in an Italian family. *Arch Intern Med* 125:337–340
- Saar K, Chrzanowska KH, Stumm M, Jung M, Nürnberg G, Wienker F, Seemanová E, et al (1997) The gene for the ataxia-telangiectasia variant, Nijmegen breakage syndrome, maps to a 1-cM interval on chromosome 8q21. *Am J Hum Genet* 60:605–610
- Sood R, Blake T, Aksentijevich I, Wood G, Chen X, Gardner D, Shelton DA, et al (1997) Construction of a 1-Mb restriction-mapped cosmid contig containing the candidate region for the familial Mediterranean fever locus (*MEFV*) on chromosome 16p13.3. *Genomics* 42:83–95
- Weeks DE, Ott J, Lathrop GM (1990) SLINK: a general simulation program for linkage analysis. *Am J Hum Genet Suppl* 47:A204
- Williamson LM, Hull D, Mehta R, Reeves WG, Robinson BH, Toghiani PJ (1982) Familial Hibernian fever. *Q J Med* 51: 469–480
- Yuval Y, Hemo-Zisser M, Zemer D, Sohar E, Pras M (1995) Dominant inheritance in two families with familial Mediterranean fever (FMF). *Am J Med Genet* 57:455–457